



USER MANUAL

VERTICAL LIFELINE WITH FALL ARRESTOR

THIS MANUAL IS INTENDED TO MEET THE MANUFACTURER'S INSTRUCTIONS AS REQUIRED BY CSA Z259.2.5-2017
IN CANADA AND SHOULD BE USED AS PART OF AN EMPLOYEE TRAINING PROGRAM AS REQUIRED BY OSHA



105718

PLEASE READ AND SAVE THESE INSTRUCTIONS

This manual is intended to meet the Manufacturer's Instructions as required by CSA Z259.2.5-2017 in Canada and should be used as part of an employee training program as required by OSHA.

FIGURE 1 - SYNTHETIC ROPE GRAB

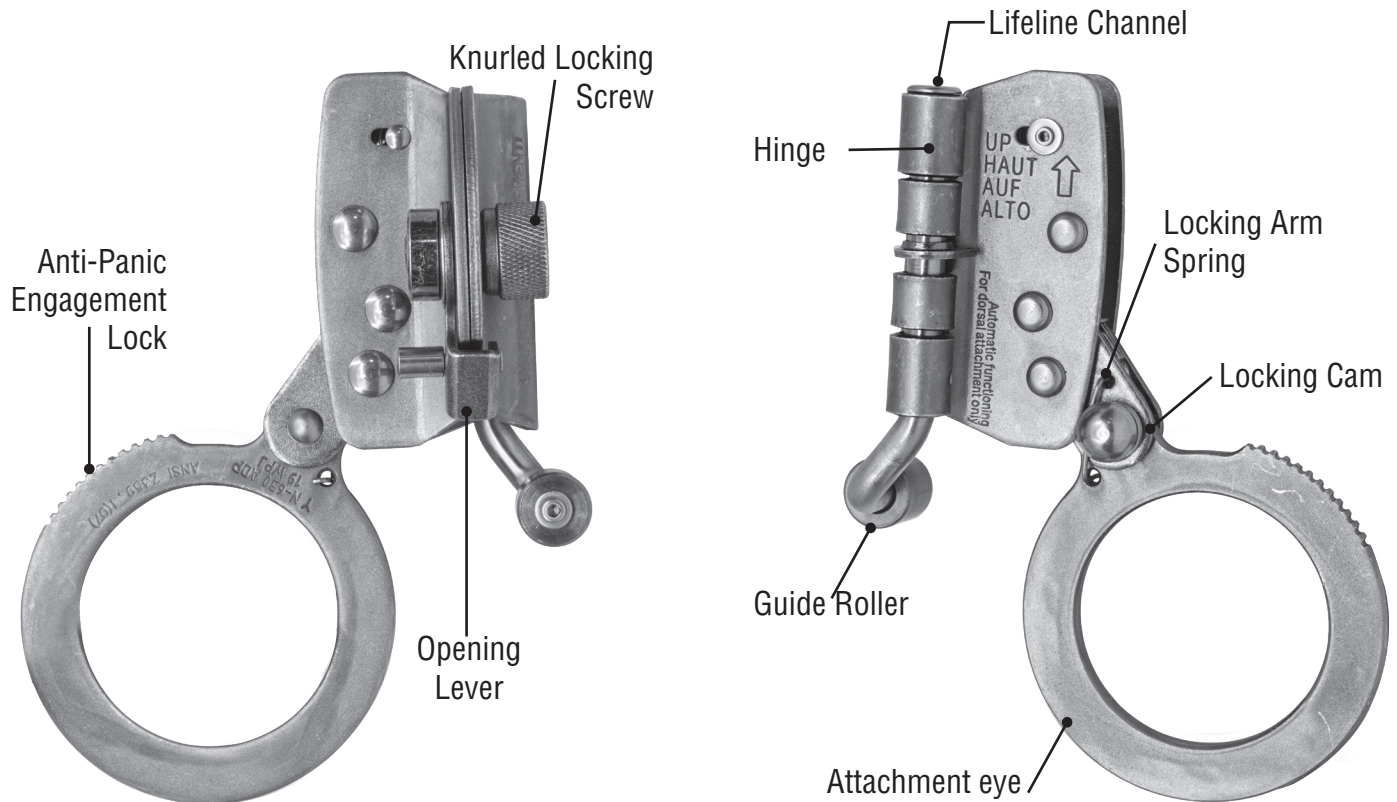

FIGURE 1 -1 SYNTHETIC VERTICAL LIFELINE



5/8" ROPE VERTICAL LIFELINE

This manual is intended to meet the manufacturer's Instructions as required by the following standards and should be used as part of an employee training program as required by OSHA:

CSA Z259.2.5-2017

1.0 APPLICATION

1.1 **PURPOSE:** TWXpert rope grab fall arresters with vertical lifeline are intended to be used as part of a personal fall arrest or restraint system. Applications for this type of product include: inspection work, construction and demolition, maintenance, oil production, window washing, and other activities where the need exists for fall arrest or restraint. See Figure 2. The following definitions describe these applications:

- A. **FALL ARREST:** used as part of a complete fall arrest system. Such systems generally include: a lifeline, rope grab, lanyard and full body harness (body support). Applications include protection of a worker on scaffolding, powered platforms, or riding a boatswain's chair. Maximum permissible free fall is 6 feet.
- B. **RESTRAINT:** used in combination with a lifeline, lanyard or connector, and body support to restrain the user from reaching a hazard (sloped or leading-edge roof work). No vertical free fall is possible.

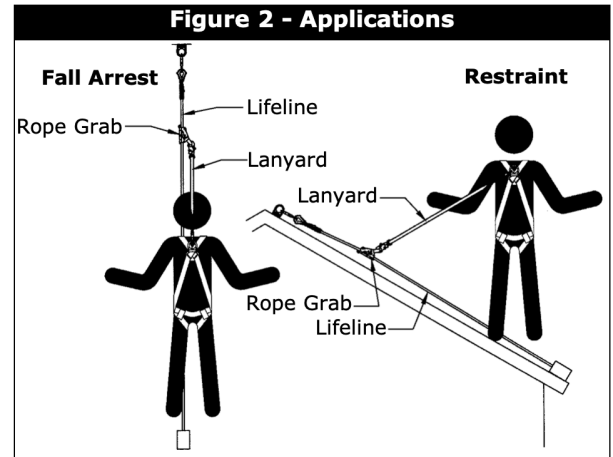

1.2 THE FOLLOWING APPLICATION LIMITATIONS MUST BE CONSIDERED BEFORE USING THIS PRODUCT:

- A. **CAPACITY:** This equipment is designed for use by persons with a combined weight (person, clothing, tools, etc.) of no more than 310 lbs. NOTE: No more than one person may be attached to a single lifeline.
- B. **FREE FALL:** Restraint systems must be rigged such that there is no possible vertical free fall. Personal fall arrest systems must be rigged in such a way to limit the free fall to 6 feet (CSA259.2.5-2017). See associated connecting subsystem manufacturer's instructions for further information.
- C. **FALL CLEARANCE:** Make certain that enough clearance exists in your fall path to prevent striking an object. The amount of clearance required is dependent upon the type of connecting subsystem used (lanyard, lifeline), the anchorage location, and the amount of stretch in the lifeline. See section 3.2 for more information on determining fall clearance.
- D. **CORROSION:** Do not leave this equipment for long periods in environments where corrosion of metal parts could take place as a result of vapors from organic materials. Sewage and fertilizer plants, for example, have high concentrations of ammonia. Use near seawater or other corrosive environments may require more frequent inspections or servicing to ensure corrosion damage is not affecting the performance of the product.
- E. **CHEMICAL HAZARDS:** Solutions containing acids, alkali, or other caustic chemicals, especially at elevated temperatures, may cause damage to this equipment. When working with such chemicals, frequent inspection of this equipment must be performed. Consult TOOLWAY if doubt exists concerning using this equipment around chemical hazards.
- F. **HEAT:** This equipment is not designed for use in high temperature environments. Protection should be provided for this equipment when used near welding, metal cutting, or similar activities. Hot sparks may burn or damage this equipment. Consult TOOLWAY for details on high temperature environments.

- G. **ELECTRICAL HAZARDS:** Due to the possibility of electric current flowing through this equipment or connecting components, use extreme caution when working near high voltage power lines.
 - H. **COMPONENT COMPATIBILITY:** The rope grab addressed by these instructions is intended for use with TWXpert lifelines and lifeline subsystems only. Consult TOOLWAY if you are considering using this equipment with other lifelines or lifeline subsystems. See section 2.0.
 - I. **TRAINING:** This equipment is to be used by persons who have been properly trained in its correct application and use.
- 1.3 Refer to applicable local, state, and federal (OSHA) requirements governing this equipment for more information on rope grabs and associated system components, including CSA259.2.5-217, and OSHA 1910.66, appendix C.

2.0 SYSTEM REQUIREMENTS

- 2.1 **COMPATIBILITY OF COMPONENTS:** TWXpert equipment is designed for use with TWXpert approved components and subsystems only. Substitutions or replacements made with non-approved components or subsystems may jeopardize compatibility of equipment and may affect the safety and reliability of the complete system.
- 2.2 **COMPATIBILITY OF CONNECTORS:** Connectors are considered to be compatible with connecting elements when they have been designed to work together in such a way that their sizes and shapes do not cause their gate mechanisms to inadvertently open regardless of how they become oriented. Contact TOOLWAY if you have any questions about compatibility.

Connectors (hooks, carabiners, and D-rings) must be capable of supporting at least 5,000 lbs. (22.2 kN). Connectors must be compatible with the anchorage or other system components. Do not use equipment that is not compatible. Non-compatible connectors may unintentionally disengage. See Figure 3. Connectors must be compatible in size, shape, and strength. Self-locking snap hooks and carabiners are required by CSA Z259.12 and OSHA.

- 2.3 **MAKING CONNECTIONS:** Only use self-locking snap hooks and carabiners with this equipment. Only use connectors that are suitable to each application. Ensure all connections are compatible in size, shape and strength. Do not use equipment that is not compatible. Ensure all connectors are fully closed and locked.

TWXpert connectors (snap hooks and carabiners) are designed to be used only as specified in each product's user instructions. See Figure 4 for inappropriate connections. TWXpert snap hooks and carabiners should not be connected:

- A. To a D-ring to which another connector is attached.
- B. In a manner that would result in a load on the gate.

NOTE: Large throat-opening snap hooks should not be connected to standard size D-rings or similar objects which will result in a load on the gate if the hook or D-ring twists or rotates. Large throat snap hooks are designed for use on fixed structural elements such as rebar or cross members that are not shaped in a way that can capture the gate of the hook.

- C. In a false engagement, where features that protrude from the snap hook or carabiner catch on the anchor and, without visual confirmation, seem to be fully engaged to the anchor point.

- D. To each other.
- E. Directly to webbing or rope lanyard or tie-back (unless the manufacturer's instructions for both the lanyard and connector specifically allows such a connection).
- F. To any object which is shaped or dimensioned such that the snap hook or carabiner will not close and lock, or that roll-out could occur.
- G. In a manner that does not allow the connector to align properly while under load.

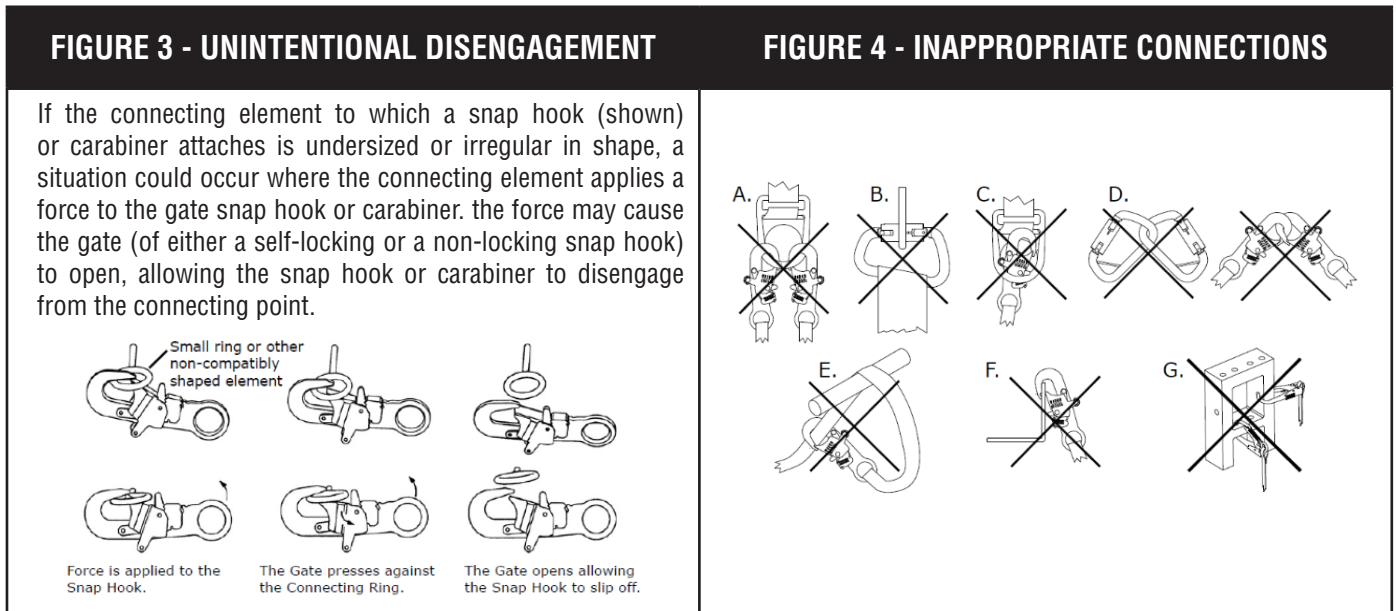

2.4 ANCHORAGE STRENGTH: The anchorage strength required is dependent upon the application. The following lists guidelines for specific application types:

- A. **FALL ARREST:** Anchorages selected for personal fall arrest systems (PFAS) shall have a strength capable of sustaining static loads, applied in the directions permitted by the PFAS, of at least: (A) 3,600 lbs. (16 kN) when certification exists (see CSA259.2.5-2017 for certification definition), or (B) 5,000 lbs. (22.2 kN) in the absence of certification. When more than one PFAS is attached to an anchorage, the anchorage strengths set forth in (A) and (B) above shall be multiplied by the number of personal fall arrest systems attached to the anchorage.

Per OSHA 1926.500 and 1910.66: Anchorages used for attachment of PFAS shall be independent of any anchorage being used to support or suspend platforms, and capable of supporting at least 5,000 lbs. (22.2 kN) per user attached, or be designed, installed, and used as part of a complete PFAS, which maintains a safety factor of at least two, and is supervised by a qualified person.

Note: When more than one Fall Arrest system is attached to an anchorage, the strength specified above shall be multiplied by the number of systems attached to the anchorage

- B. **RESTRAINT:** Anchorages must be capable of supporting a minimum of 3,000 lbs. per system attached.

2.5 LIFELINES: Lifelines used are: 5/8-inch (16mm) diameter polyester/polypropylene blend rope assembly, 5/8-inch (16mm) diameter polyester/polypropylene blend rope. See Section 7.0 for lifeline specifications and Section 7.3 for elongation factors.

- 2.6 **LANYARD:** The fall arrester which integral to the rope grab must not exceed 30inch (750mm) and have a minimum breaking strength of 5000lbs (22.5KN)
- 2.7 **BODY SUPPORT:** The recommended body support for fall arrest applications is a full body harness, for restraint applications a body belt may be used.

IMPORTANT: Only lifeline ropes which meet the size, construction, and material properties required for compatible use with this rope grab may be used.

NOTE: Applications such as working near high voltage may require special lifeline materials, consult TOOLWAY before using such lifelines.

3.0 OPERATION AND USE

3.1 **BEFORE EACH USE** of this equipment, carefully inspect it to ensure that it is in good working condition. See section 5.0 for inspection details. Do not use if inspection reveals an unsafe condition.

3.2 **PLAN** your fall arrest or restraint system before starting your work. Consider all factors that affect your safety before, during, and after a fall. Refer to these and related subsystem component instructions, and state and federal safety regulations for guidance in planning your system. The following list gives some important points to consider when planning your system:

WARNING: Do not alter or intentionally misuse this equipment. Consult TOOLWAY if using this equipment with components or subsystems other than those described in this manual. Some subsystem and component combinations may interfere with the operation of this equipment.

WARNING: Do not use this equipment if you are unable to tolerate the impact from a fall arrest. Age and fitness can seriously affect your ability to withstand a fall. Pregnant women and minors must not use this equipment.

- A. **ANCHORAGE:** Select a rigid anchorage point that is capable of supporting the required loads. See section 2.4. The anchorage location must be carefully selected to reduce possible free fall and swing fall hazards and to avoid striking an object during a fall. For restraint systems, the anchorage must be located such that no vertical free fall is possible. For fall arrest systems, OSHA requires the anchorage be independent of the means suspending or supporting the user.

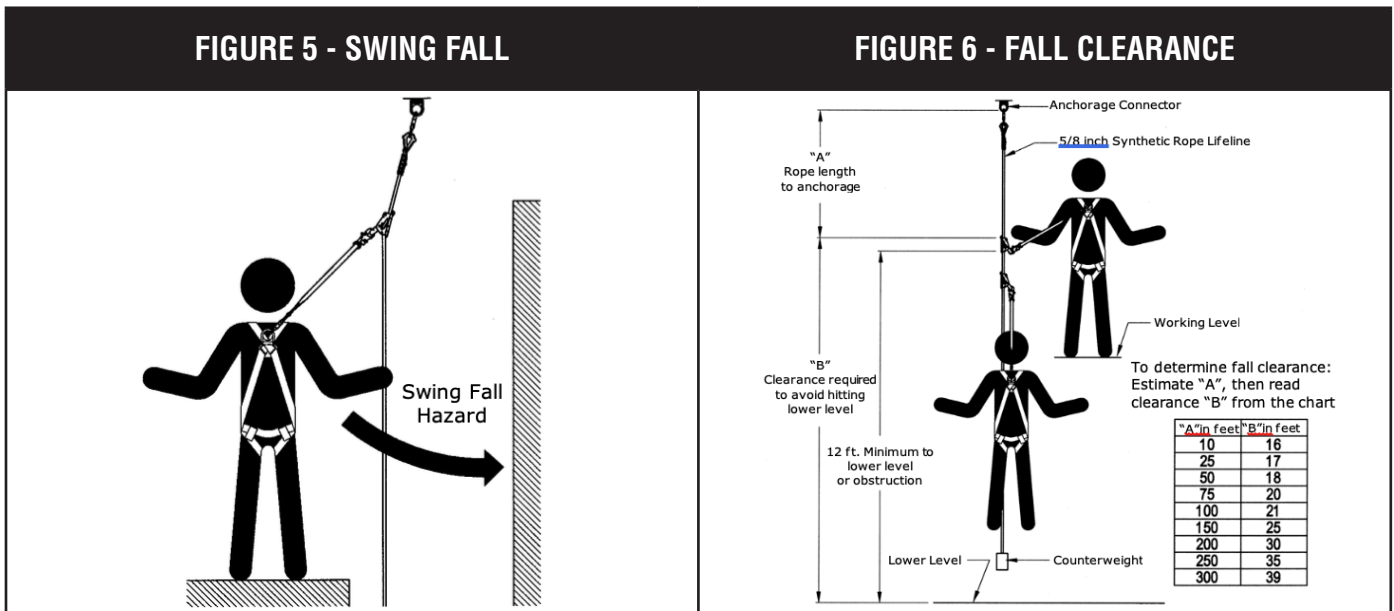

- B. **FREE FALL:** Do not work above the anchorage level; increased fall distance will result. Personal fall arrest systems must be rigged such that the potential free fall is never greater than 6 feet. Restraint systems must be rigged such that there is no possible vertical free fall.
- C. **FALL ARREST FORCES:** The assembled fall arrest system must keep fall arrest forces below 1,800 lbs. when used with a full body harness. Do not use a body belt for fall arrest.

- D. **SWING FALLS:** Swing falls occur when the anchorage point is not directly above the point where a fall occurs. The force of striking an object while swinging can be great and cause serious injury. Swing falls can be minimized by working as directly below the anchorage as possible. See Figure 5.
- E. **FALL CLEARANCE:** Make certain enough clearance exists in your fall path to prevent striking an object. The amount of clearance needed is dependent upon the type of connecting subsystem used and anchorage location. See Figure 6 for estimating fall clearance.
- F. **SHARP EDGES:** Avoid working where parts of the system will be in contact with, or abrade against, unprotected sharp edges.
- G. **RESCUE:** The user must have a rescue plan and the means at hand to implement it if a fall occurs.
- H. **AFTER A FALL:** Components which have been subjected to the forces of arresting a fall must be removed from service immediately and destroyed.
- I. **GENERAL USE CONSIDERATIONS:** Avoid working where lifeline may cross or tangle with that of another worker. Do not allow the lanyard to pass under arms or between legs. Do not clamp, tie or otherwise prevent the rope grab lanyard connection handle from moving freely into the “locked” position.
- J. **SLOPED ROOFS:** Provisions must be made (warning lines, monitors, guardrails) to prevent swing falls from unprotected roof edges or corners. The rope grab should be connected to the body support using a locking carabiner (direct connection) or a short lanyard. If a lanyard is used for connecting to the rope grab, keep the length as short as possible, and never greater than 3 feet. The lifeline must be protected from contact with sharp or abrasive edges and surfaces. The rope grab locking operation must not be hindered by interference with the roof or objects on the roof surface.
- K. **UNSTABLE SURFACES:** The rope grab is not suitable for use on unstable or slowly shifting materials, such as sand or grain.

WARNING: Never connect more than one personal fall arrest or restraint system to a single lifeline or rope grab.

WARNING: Follow manufacturer's instructions for associated equipment used in your fall protection or restraint system.

IMPORTANT: For custom versions of this product, follow the instructions herein. If included, see supplemental instructions for additional information.

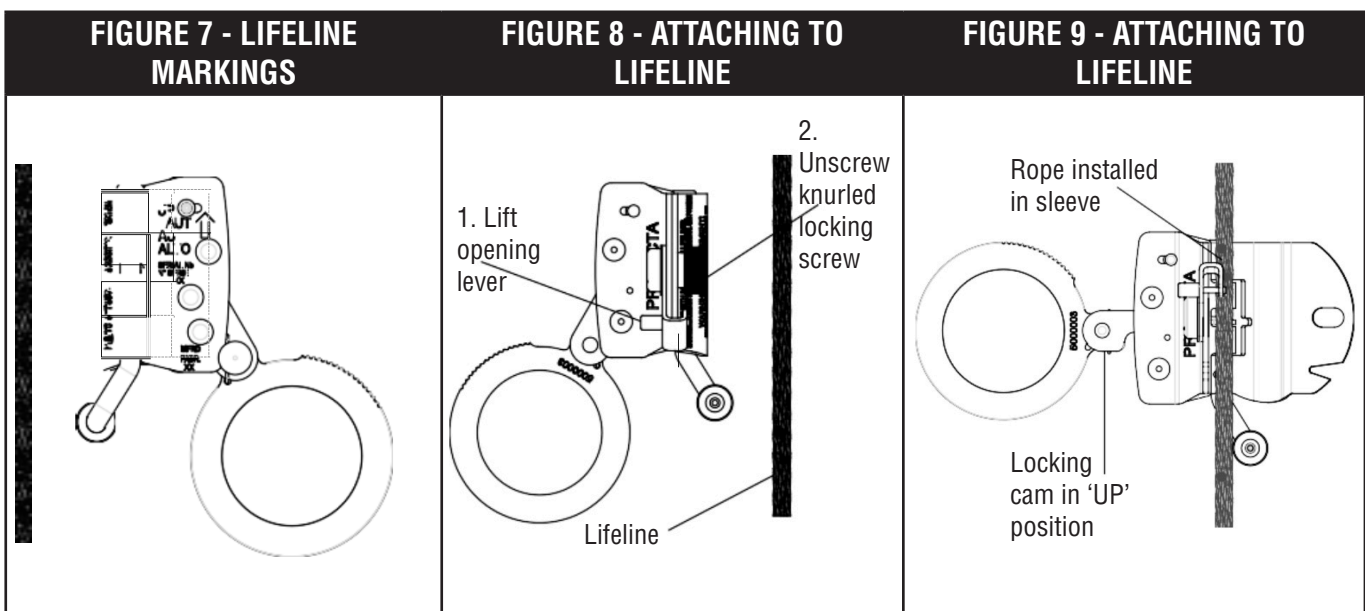

3.3 ATTACHING THE SYNTHETIC ROPE GRAB TO THE LIFELINE:

- A. Ensure the rope grab is in the “UP” position as indicated on the product. The “UP” end of the rope grab must be oriented towards the anchorage when installed onto the lifeline (see Figure 7). NOTE: The synthetic rope grab incorporates a gravity-lock bracket that slides out of the hinge pin to prevent the lifeline sleeve from mating with the rope grab cam when not held upright (see Figure 8).
- B. Unscrew the knurled knob until the hinged channel bracket opens.
- C. Pull the lifeline sleeve apart until the unit is fully opened (see Figure 9).
- D. To install on the lifeline, raise the locking cam to the “up” position and install the rope inside the lifeline channel and close the rope grab halves. Screw-in the knurled knob and slide the locking latch closed (see Figure 10).
- E. Test the rope grab operation by pulling down on the locking cam. The rope grab must lock onto the lifeline and prevent any descent on the lifeline once the cam is engaged.

3.4 POSITIONING THE ROPE GRAB ON THE LIFELINE:

- A. Using the lanyard connected to the rope grab, pull up slightly on the rope grab locking cam to release it from the locked position. Always keep a minimum of 3.7m (12 feet) of rope below the rope grab to accommodate locking distance and fall clearance.
- B. Using the connected lanyard, raise or lower the rope grab to the desired location. Apply tension to the lifeline to assure smooth travel of the rope grab on the lifeline. Lifeline tension can be achieved by adding a weight on the lifeline end or extending additional lifeline (in a hanging orientation) to provide weight.
- C. After locating the rope grab, position it on the lifeline at or above the shoulders to reduce possible free fall. Lock the rope grab at this position by pulling the locking cam until the cam lever is in the full down position. The locking cam must be released before attempting to reposition the rope grab.
- D. Under special conditions, such as working on a moving platform, it is allowable to let the rope grab follow the worker as the platform is moved. The lanyard should be kept as short as possible and must not exceed 30 inches (750mm) in length.

WARNING: Rope grab attachment and positioning instructions and procedures must be followed. Improper assembly could allow the rope grab to slip or not lock onto the lifeline in the event of a fall and may result in serious injury or death.

- 3.5 **ANTI-PANIC GRIP FEATURE:** In the event of a fall, the user may grasp the rope grab in a manner that forces the locking cam into the open position. The synthetic rope grab anti-panic grip feature has an additional cam in the center of the locking cam. This cam is pushed out and into the lifeline when the locking cam is forced beyond the open position, thus stopping a fall in spite of the locking cam being held in the open position.
- 3.6 **CONNECTING TO ANCHORAGE OR ANCHORAGE CONNECTOR:** When attaching the lifeline or lifeline subsystem to the anchorage or anchorage connector, ensure the connector (self-locking snap hook) is fully engaged and locked onto the connection point. Ensure connections are compatible in size, shape, and strength. Refer to the anchorage connector and lifeline manufacturer's instructions for further information. See Figure 11.

FIGURE 10 - ATTACHING TO LIFELINE

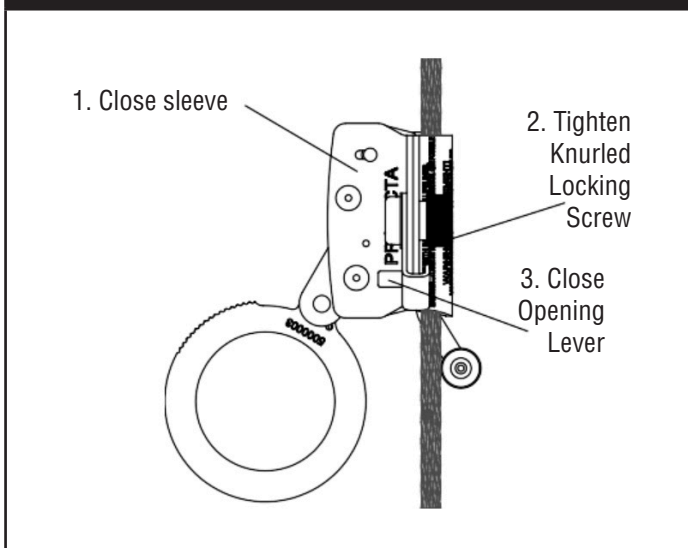
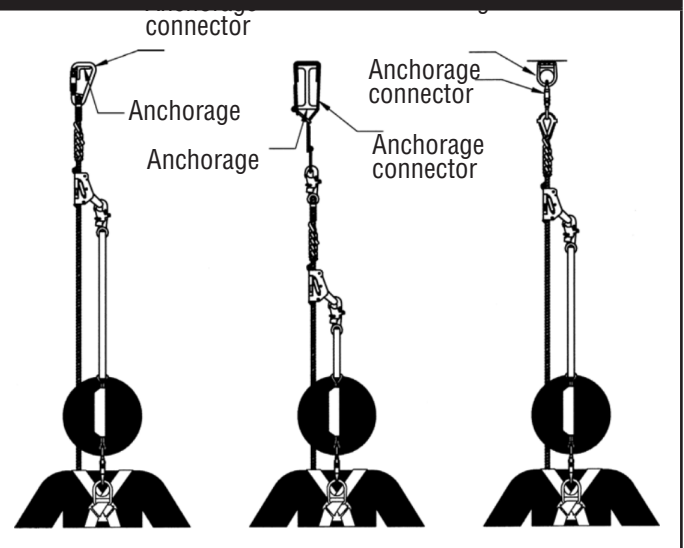

FIGURE 11 - MAKING CONNECTIONS



- 3.7 **CONNECTING TO THE BODY SUPPORT:** For fall arrest applications, connect to the dorsal D-ring located between the shoulders on the back of the full body harness. For restraint applications, the dorsal or frontal harness attachment may be used. If using a body belt for restraint applications connect to the D-ring opposite the restraining load. Ensure connections are compatible in size, shape, and strength. Refer to the body support manufacturer's instructions for more information on making connections.
- 3.8 **CONNECTING TO THE ROPE GRAB:** When connecting an energy absorbing lanyard to the rope grab, attach the lanyard end (vs. the energy absorber end) to the rope grab to reduce possible interference with the operation of the rope grab by the energy absorber "pack". Some rope grab models may be supplied with a permanently attached lanyard or energy absorber. Do not attempt to attach additional lanyards or connectors to these subsystems. If using a carabiner to connect directly to the rope grab, ensure the carabiner will not interfere with the operation of the rope grab. Carabiners must be of the self-closing/self-locking type. Ensure connections are compatible in size, shape, and strength. Ensure the connector attached to the rope grab allows the handle to rotate freely, and does not interfere with the rope grab operation.

3.9 USE OF LIFELINES:

- Always protect the lifeline if passing over or around sharp edges. Sharp edges can reduce rope strength by 70% or more.
- Keep lifelines clean.
- Avoid twisting or kinking lifelines when coiling or uncoiling.
- Avoid using lifelines near acids or alkali. If the lifeline is used around any chemical or compound, watch for signs of deterioration.
- Never use a knotted lifeline, knots can reduce rope strength by 50%.
- Store lifelines properly. See section 6.0.

3.10 **AFTER USE** of the rope grab fall arrester & vertical life and its subsystem components, return it for cleaning or storage as described in section 6.0.

4.0 TRAINING

4.1 **TRAINING:** The user, and the user's employer, must be trained in the correct use and care of this equipment. Both parties must be aware of the operating characteristics, application limits, and consequences of improper use of this equipment.

IMPORTANT: Training must be conducted without exposing the trainee to a fall hazard. Training should be repeated on a periodic basis.

5.0 INSPECTION

5.1 FREQUENCY:

- A. **Before Each Use**, visually inspect the equipment per steps listed in section 5.2, 5.3, and 5.4.
- B. The fall arrester must be inspected by a competent person¹ other than the user at least annually. See sections 5.2, 5.3, and 5.4 for guidelines. Record the results of each formal inspection in the inspection log found in section 9.0. NOTE: CSA/OSHA requires personal fall arrest systems be inspected prior to each use for wear, damage, and defects and inspected by a competent person* at least twice a year, in accordance with the manufacturer's recommendations, with inspection dates documented.

IMPORTANT: If the rope grab fall arrester has been subjected to fall arrest or impact forces, it must be immediately removed from service and destroyed.

IMPORTANT: Extreme working conditions (harsh environments, prolonged use, etc.) may require increasing the frequency of inspections.

5.2 INSPECTION STEPS FOR ROPE GRAB FALL ARRESTER: See Figure 1.

- Step 1.** Inspect the attachment eye and locking cam to ensure that the cam moves freely without hesitation, binding or sticking.
- Step 2.** Inspect the locking cam and ensure that the teeth are not rounded or worn.
- Step 3.** Inspect the locking cam lever spring and auto-locking lever springs. Ensure they are in the proper location and undamaged.
- Step 4.** Inspect the spring for the locking pin (located in the groove) and ensure it is the proper location and undamaged.
- Step 5.** The two halves of the rope grab must close and open freely on the hinge. Inspect the lifeline channel and ensure that there are no dips or depressions worn into the channel and that the dimples are without damage. Ensure all the labels and engravings are legible.
- Step 6.** Inspect the hinge, attachment eye, and the rest of the rope grab for signs of corrosion, wear, cracks, distortion or other damage.
- Step 7.** With the rope grab open and upside-down, the gravity-lock bracket should drop down and prevent the rope grab from closing
- Step 8.** To test the Panic Lock feature, install rope grab on lifeline. Pass the thumb on one hand through the attachment eye and grasp the rope grab body with the rest of the hand. Force the eye to open the locking lever until it stops. Run the rope grab down the lifeline and ensure that it locks onto the lifeline.
- Step 9.** Record the inspection date and results in the inspection log in section 9.0.

5.3 INSPECTION STEPS FOR LIFELINE: (See the Lifeline User Instruction Manual for complete details)

Step 1. Lifeline hardware must not be damaged, broken, distorted, or have any sharp edges, burrs, cracks, worn parts, or corrosion. Ensure the connecting hooks work properly. Hook gates must move freely and lock upon closing.

Step 2. Inspect the rope for concentrated wear. The material must be free of frayed strands, broken yarns, cuts, abrasions, burns, and discoloration. The rope must be free of knots, excessive soiling, heavy paint buildup, and rust staining. Rope splices must be tight, with five full tucks, and thimbles must be held by the splice. Cracked or distorted rope thimbles may indicate that the lifeline has been impact loaded. Check for chemical or heat damage (indicated by brown, discolored, or brittle areas). Check for ultraviolet damage, indicated by discoloration and the presence of splinters and slivers on the rope surface. All of the above factors are known to reduce rope strength. Damaged or questionable ropes must be replaced.

Step 3. Inspect labels. All labels must be present and fully legible. Replace labels if illegible or missing

Step 4. Record the inspection date and results in the inspection log found in the Lifeline user instruction manual.

1 *Competent Person:* *An individual knowledgeable of a manufacturer's recommendations, instructions and manufactured components who is capable of identifying existing and predictable hazards in the proper selection use and maintenance of fall protection.*

5.4 If inspection reveals a defective condition, remove the unit from service immediately and destroy, or contact a factory authorized service center for repair.

IMPORTANT: Do not attempt to alter, repair, or make substitutions to the rope grab or rope grab parts. Equipment found to be in defective condition must be removed from service. Repairs may only be performed by Capital Safety or those authorized in writing to do so.

6.0 MAINTENANCE

- 6.1 Clean the rope grab and lifeline with water and a mild soap solution. Wipe off hardware with a clean, dry cloth, and hang to air dry. Do not force dry with heat. An excessive buildup of dirt, paint, etc. may prevent the rope grab or lifeline from working properly, and in severe cases degrade the rope grab or rope to a point where it has weakened and should be removed from service. If you have any questions concerning the condition of the rope grab or lifeline, or have any doubt about putting them into service, contact TOOLWAY. See the Lifeline User Instruction Manual for specific maintenance details.
- 6.2 Additional maintenance and servicing procedures (replacement parts) must be completed by a factory authorized service center. Authorization must be in writing. Do not attempt to disassemble the unit. See section 5.1 for inspection frequency.
- 6.3 Store the rope grab and lifeline in a cool, dry, clean environment out of direct sunlight. Avoid areas where chemical vapors may exist. Thoroughly inspect the rope grab and lifeline after any period of extended storage.

7.0 SPECIFICATIONS / PERFORMANCE DATA

7.1 MATERIALS:

Material: All material used in construction is certified to be new and free from defects.

Construction: Riveted and welded with hinged rope channel.

Material Type:

Rope Grab: Body, hinge, cam, and attachment eye – High impact resistant steel

Fall Arrester: 100% Polyester

7.2 PERFORMANCE:

Maximum Arresting Distance: 1 meter (39 inch) when dynamically tested in accordance with CAN/

NOTE: This does not include lifeline elongation.

Arrest Force: Designed for 1,800 lbs. maximum arresting force

Maximum Capacity: 141 kg or 310 lbs.

Requirements: Meets applicable CAN/CSA Z259.2.5-2017 and applicable OSHA standards, including 1910.66.

Parking Feature: Allows manual operation as required

7.3 LIFELINE SPECIFICATIONS:

Lifeline Diameter: 16mm (5/8 inch)

Material: Polyester and polypropylene

Color: White with orange or green marker yarns **Construction:** Three strand, right hand lay **Hardness:** 5-15 lbs

Linear Density: 9.5 lbs/100 ft., nominal

Tensile Strength: 6,000 lbs (27.0 kNs)

Certification: CSA Z259.2.5-2017

TABLE 1 - LIFELINE ELONGATION

Lifeline Length ft. (m)								
Lifeline Material	25' (7.6 m)	50' (15.2 m)	75' (22.9 m)	100' (30.5 m)	150' (45.7 m)	200' (61.0 m)	250' (76.2 m)	300' (91.4 m)
5/8" Polyester	2.5'	5'	7.5'	10'	15'	20'	25'	30
Polypropylene	(0.8 m)	(1.5 m)	(2.3 m)	(3.0 m)	(4.6 m)	(6.1 m)	(7.6 m)	(9.1 m)

8.0 LABELING

8.1 The following labels and markings must be present and fully legible:

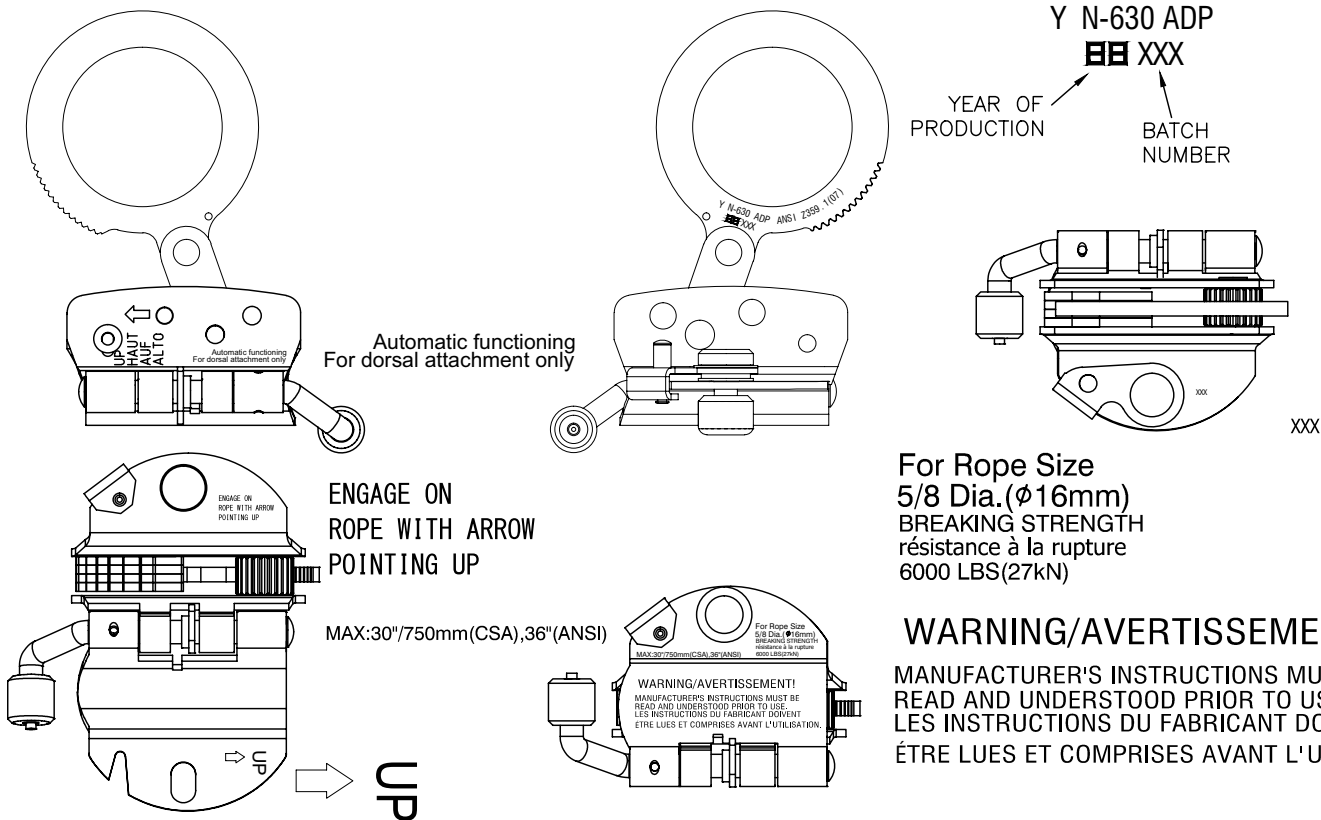



TWX PERT

**MEETS AND EXCEEDS
CSA Z259.2.5-2017**

MODEL/MODÈLE: 105718
SERIAL/SÉRIE: 000001

LENGTH/LONGUERUR:
50ft (15m)

MATERIAL/MATÉRIEL:
Polyester & Polypropylene Blend

MFR DATE: YYYY/MM

Capacity/Capacité:
310 lbs (140kg)

WARNING: Follow
manufacturer's instructions.
AVERTISSEMENT: Suivre les
Suivre les instructions du fabricant.



 Imported by | Importé par
 Toolway Industries Ltd. L4H 3V9

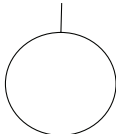

User must inspect
before each use.
L'utilisateur doit
inspecter avant
chaque utilisation

												YR
												J
												F
												M
												A
												M
												J
												J
												A
												S
												O
												N
												D

USER/UTILISATEUR:



TWX PERT

**MEETS AND EXCEEDS
CSA Z259.2.5-2017**

LENGTH/LONGUERUR:
36" (0.75m)

MATERIAL/MATÉRIEL:
Polyester & Polypropylene Blend

MFR DATE: YYYY/MM

Capacity/Capacité:
310 lbs (140kg)

WARNING: Follow
manufacturer's instructions.
AVERTISSEMENT: Suivre les
Suivre les instructions du fabricant.



 Imported by | Importé par
 Toolway Industries Ltd. L4H 3V9



User must inspect
before each use.
L'utilisateur doit
inspecter avant
chaque utilisation

												YR
												J
												F
												M
												A
												M
												J
												J
												A
												S
												O
												N
												D

USER/UTILISATEUR:

INSPECTION AND MAINTENANCE LOG

SERIAL NUMBER:			
MODEL NUMBER:			
DATE PURCHASED:		DATE OF FIRST USE:	

INSPECTION DATE	INSPECTION ITEMS NOTED	CORRECTIVE ACTION	MAINTENANCE PERFORMED
Approved By:			
Approved By:			
Approved By:			
Approved By:			
Approved By:			
Approved By:			
Approved By:			
Approved By:			
Approved By:			
Approved By:			
Approved By:			
Approved By:			
Approved By:			
Approved By:			
Approved By:			

LIMITED LIFETIME WARRANTY

Warranty to End User: TOOLWAY warrants to the original end user (“End User”) that its products are free from defects in materials and workmanship under normal use and service. This warranty extends for the lifetime of the product from the date the product is purchased by the End User, in new and unused condition, from a TOOLWAY authorized distributor.

TOOLWAY’S entire liability to End User and End User’s exclusive remedy under this warranty is limited to the repair or replacement in kind of any defective product within its lifetime (as TOOLWAY in its sole discretion determines and deems appropriate). No oral or written information or advice given by TOOLWAY, its distributors, directors, officers, agents or employees shall create any different or additional warranties or in any way increase the scope of this warranty. TOOLWAY will not accept liability for defects that are the result of product abuse, misuse, alteration or modification, or for defects that are due to a failure to install, maintain, or use the product in accordance with the manufacturer’s instructions.

TOOLWAY’S WARRANTY APPLIES ONLY TO THE END USER. THIS WARRANTY IS THE ONLY WARRANTY APPLICABLE TO OUR PRODUCTS AND IS IN LIEU OF ALL OTHER WARRANTIES AND LIABILITIES, EXPRESSED OR IMPLIED. TOOLWAY EXPRESSLY EXCLUDES AND DISCLAIMS ANY IMPLIED WARRANTIES OF MERCHANTABILITY OR FITNESS FOR A PARTICULAR PURPOSE, AND SHALL NOT BE LIABLE FOR INCIDENTAL, PUNITIVE OR CONSEQUENTIAL DAMAGES OF ANY NATURE, INCLUDING WITHOUT LIMITATION, LOST PROFITS, REVENUES, OR PRODUCTIVITY, OR FOR BODILY INJURY OR DEATH OR LOSS OR DAMAGE TO PROPERTY, UNDER ANY THEORY OF LIABILITY, INCLUDING WITHOUT LIMITATION, CONTRACT, WARRANTY, STRICT LIABILITY, TORT (INCLUDING NEGLIGENCE) OR OTHER LEGAL OR EQUITABLE THEORY.



Head Office: 1-280 Hunter's Valley Road, Woodbridge, ON, Canada L4H 3V9 | Phone: (905) 326-5450 | Fax: (905) 326-5451
Montreal: 1868 Blvd. Des Sources, Suite 115, Pointe-Claire, QC, Canada H9R 5R2 | Phone : (514) 316-6062 | Fax: (514) 695-1761
For Customer Assistance: Toll Free: 1-(800)-705-4454 | email: info@toolway.com | website: www.toolway.com